



# BELFLOWER

## 3D PAPER-CRAFT MODEL



lowPolysm

Hooray! You are about to start a wonderful and fun journey of assembling your own **lowPolysm BELLFLOWER** 3D papercraft model. Follow the simple instructions below and find out how easy and satisfying it is to create something with your own hands using only a few pieces of paper.

## BELLFLOWER PARAMETERS



**Model name:**

**BELLFLOWER**

**A4 | US letter papers:**

**4 sheets**

**COLOR1:**

**Purple - Flower**

**COLOR2:**

**Green - Stem, Leaves**

**COLOR3:**

**White - Stamens**

**Template parts:**

**23**



**Flaps to glue:**

**63**

**Level of difficulty:**

**Easy**

## WHAT YOU WILL NEED

 Hands	 Printer	 Cardstock 4 sheets	 Ruler
 Pen	 Scissors	 Paper glue	 Time

## WHAT NEEDS TO BE DONE

Follow the steps below to successfully assemble your own personalized **lowPolysm BELLFLOWER** 3D papercraft model.

- 01. PRINT**
  - 02. SCORE**
  - 03. CUT**
  - 04. FOLD**
  - 05. GLUE**
  - 06. FINISH**
- ENJOY**

# 01. PRINT

- Select paper and colors for your paper model. It is recommended to use the paper with following parameters:

Paper size: **A4 - 21x29.7cm | US letter - 8.5x11"**

Paper thickness: **180 - 300 g/m<sup>2</sup> | 70 - 110 lb cover**

Paper colors:



**COLOR1**  
**2 sheets**



**COLOR2**  
**1 sheet**



**COLOR3**  
**1 sheet**

or select paper colors of your choice.

- Print PDF template files on selected color papers with printing scale set to "Actual Size," "No scale," "100% size," or "1:1 ratio" based on your printer settings. Common home/office printers can handle the above paper parameters but please check just to be sure.

PDF template files:

**[BELLFLOWER-Template-PDF-COLOR1.pdf](#)**

**[BELLFLOWER-Template-PDF-COLOR2.pdf](#)**

**[BELLFLOWER-Template-PDF-COLOR3.pdf](#)**

## Printing tips & tricks:

Make sure that the 3D papercraft model with multiple PDF template files is printed with the same printing scale and settings set for all pages.

If your available printer can handle larger paper sizes you can set the printing scale to more than 100% and print PDF template file(s) scaled up to whatever paper size your printer can print. The final paper model will have equivalently larger dimensions.

It can be difficult to see printed template lines and numbers on black or dark-colored paper. In this case, print the PDF template files on a regular white thin office paper and then glue it to the desired dark-colored paper. This technique can also be used for transferring templates on paper types that can't be used in common printers (e.g. crafting paper, texture paper, metallic paper, and heavier cardstock).

You can print PDF template files on any heavier colored or textured paper and create a 3D papercraft model based on your personal style, taste and creativity.

**02. SCORE**  Score all dashed — — — — — and dotted ..... lines on printed template parts, with a ruler and dried out ballpoint pen or similarly dull item.

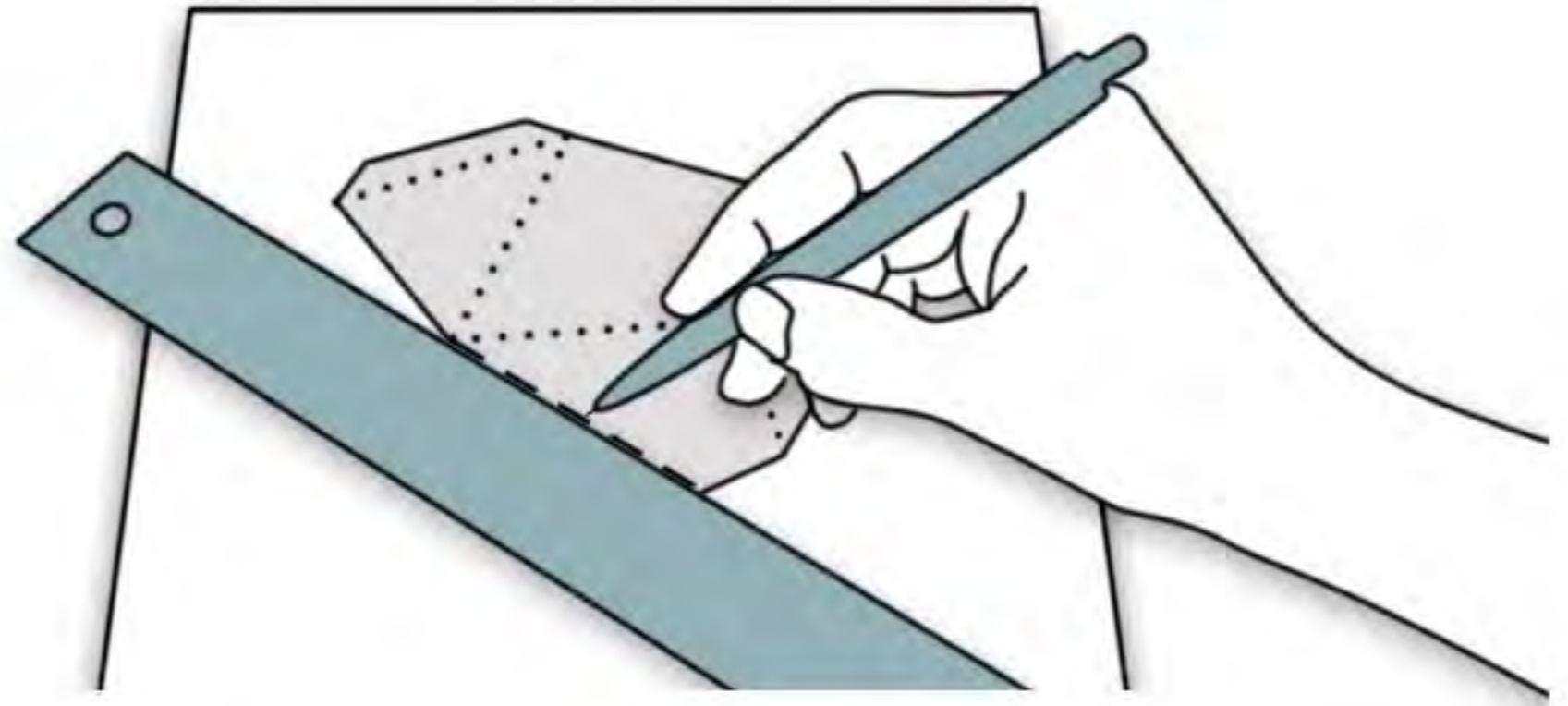

**Scoring tips & tricks:**

Be careful and gentle with scoring so you don't score through the paper. Try and test it on some scrap paper first.

You can use also other tools to score paper e.g. sharp ruler corner, pin, nail, awl, or quilling pen. Try what works best for you.

**03. CUT**  Cut template parts along all solid ————— lines.

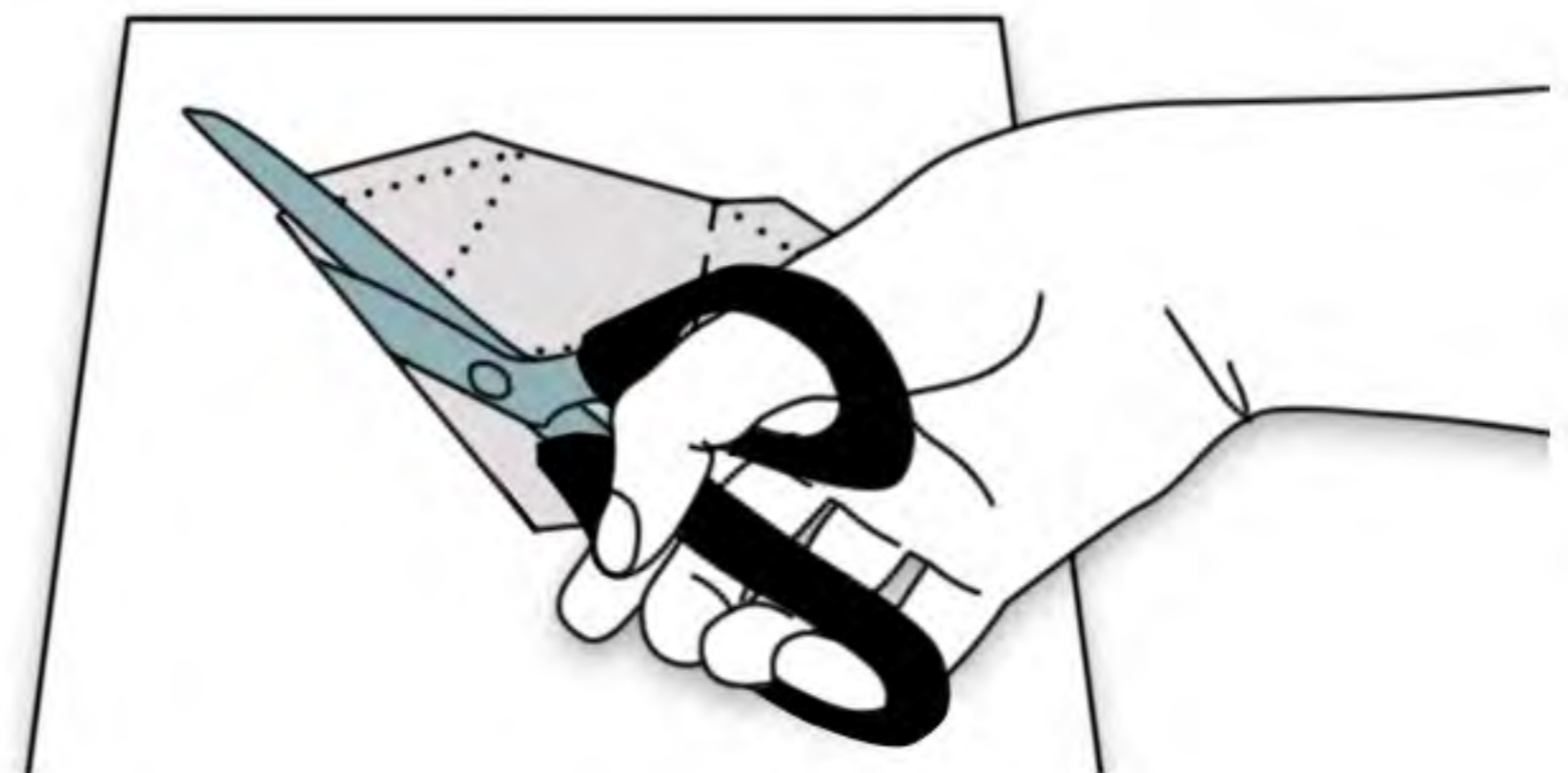

**Cutting tips & tricks:**

More precise cuts can be achieved with a ruler and crafting knife. Place the ruler along the solid line and cut with the crafting knife along the ruler edge. A metal ruler is most appropriate for this technique rather than a plastic or wooden ruler.

Be thorough, accurate, and careful while cutting. Watch your fingers and store cutting tools safely after you are finished with cutting.

## 04. FOLD

- Fold all the lines you scored. Dashed — — — — lines create mountain folds, dotted ..... lines create valley folds. Created folds are edges of your **lowPolysm** 3D papercraft model.

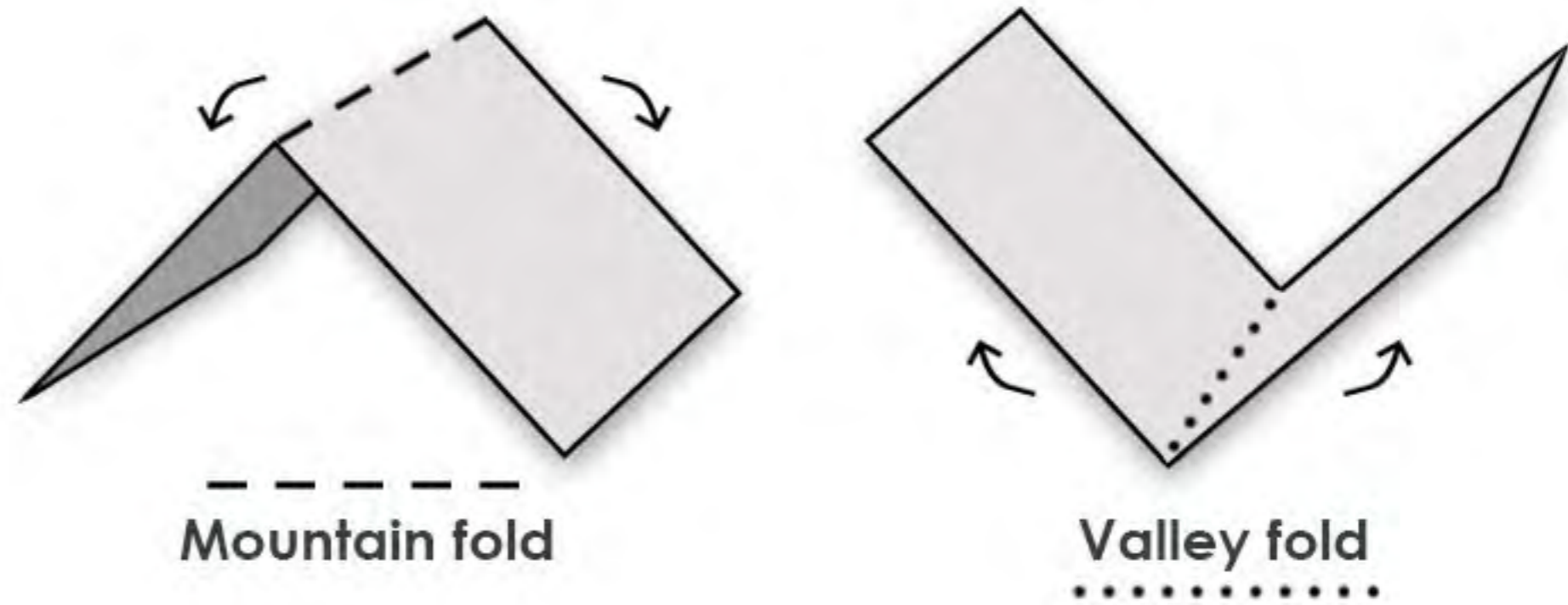

## 05. GLUE

- Glue flaps to the edges with the same numbers. Firstly glue the flaps within individual template parts.

Example:

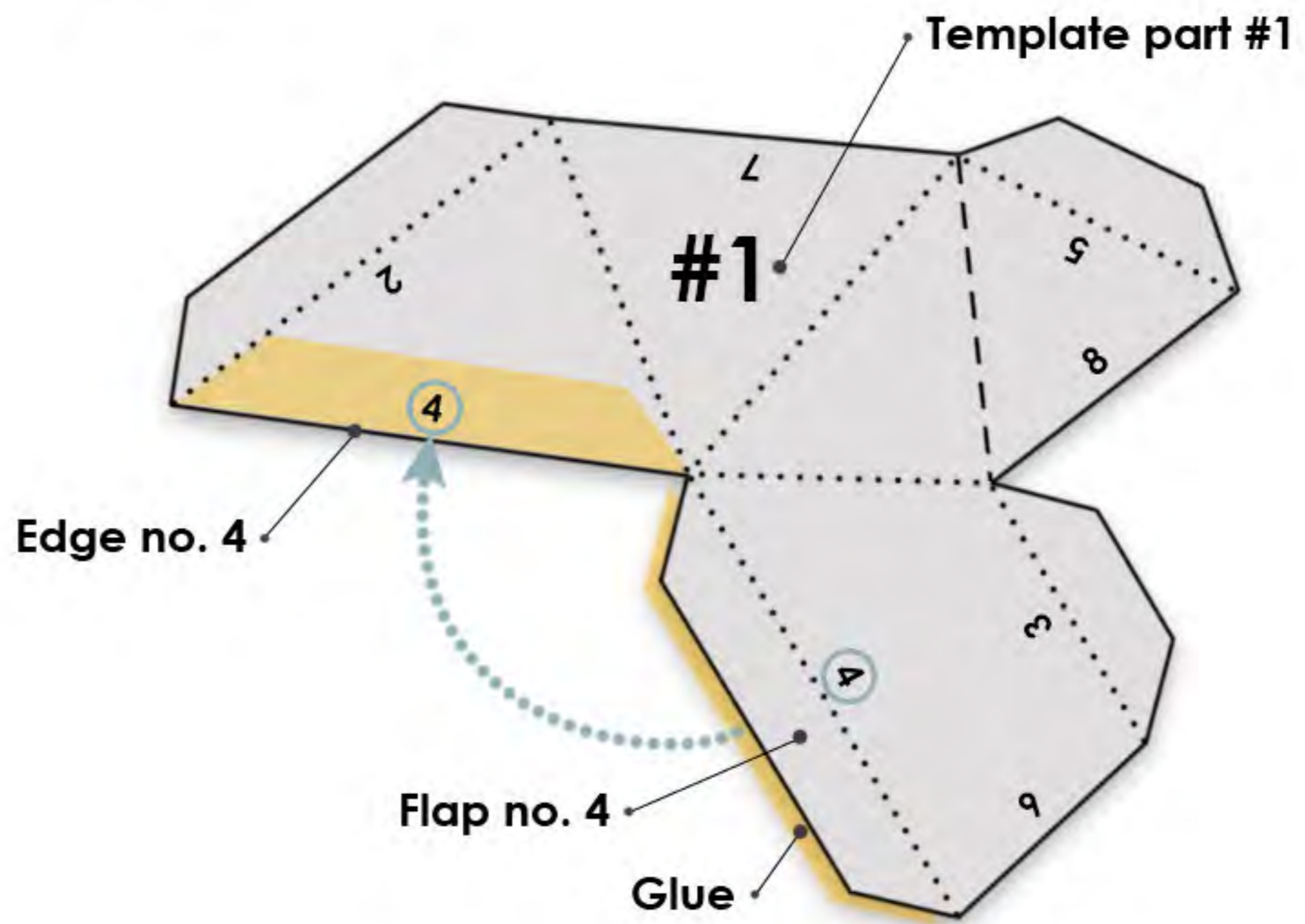

- Continue gluing flaps within the individual template parts. Then, glue all connecting flaps between template part **#1** and **#2**, then continue to **#3** and so on. The position of individual template parts and instructions with a visual assembly guide is described on the next pages.

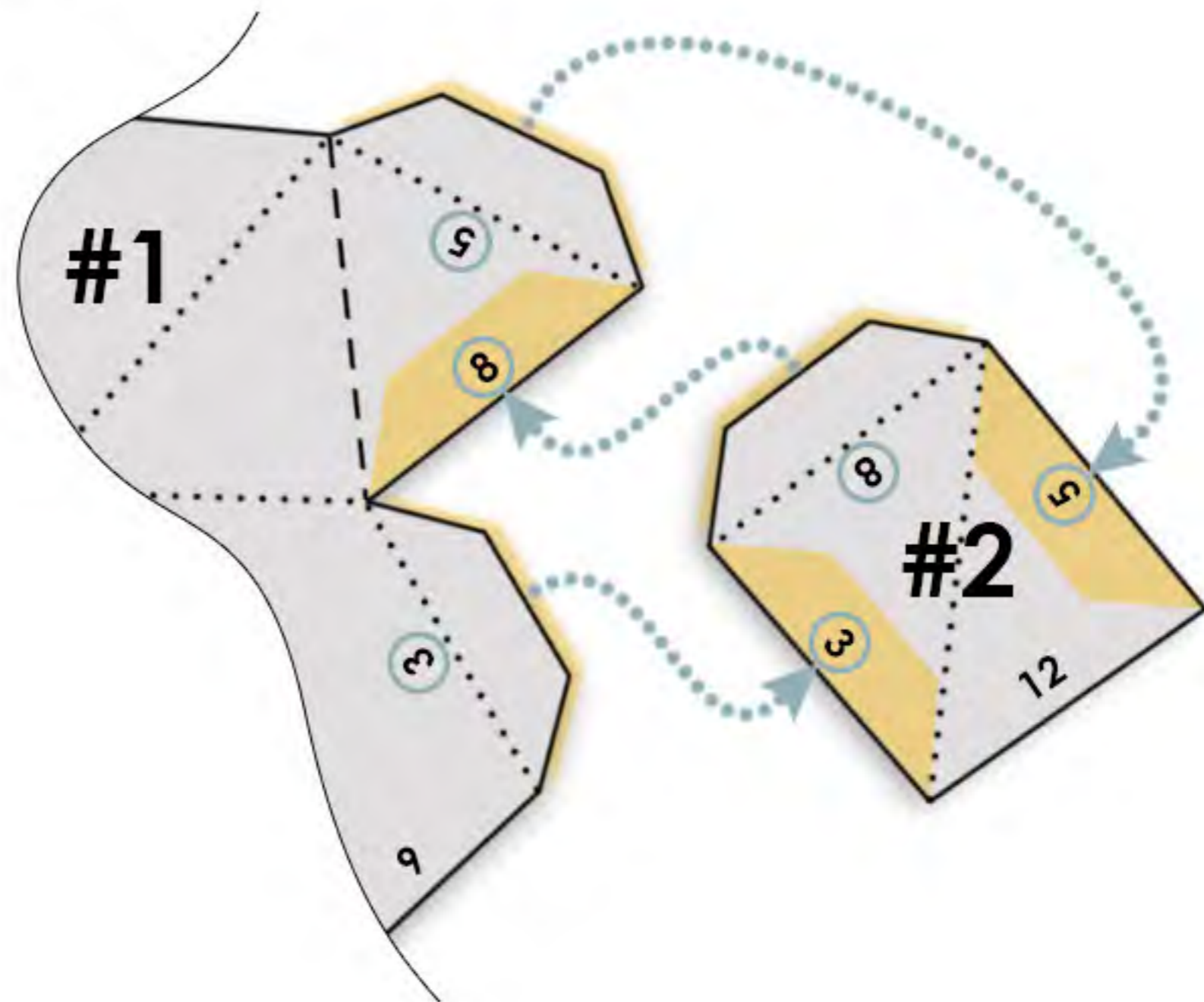

### Gluing tips & tricks:

All printed sides of the template parts are inside of the paper model. All flaps, lines, and numbers stay inside and should not be visible from the outside of the finished model.

Flap and edge numbers only indicate matching pairs that need to be glued together and do not represent the order of gluing.

Dry-fit the connecting parts first, then spread the glue evenly on the correct side of a flap.

Always glue one flap at a time and wait until it dries out.

Be accurate when gluing flaps to the edges. Both corners of a flap must precisely match both ends of the corresponding edge.

Less is more and this also applies to amount of glue you should use. Put few drops of glue on the flap spread it evenly, removing any excess glue with a toothpick or scrap paper. If using water-based glue, you can pour a small amount in a glass bowl and use a small paintbrush to apply the glue.

# TEMPLATE PARTS

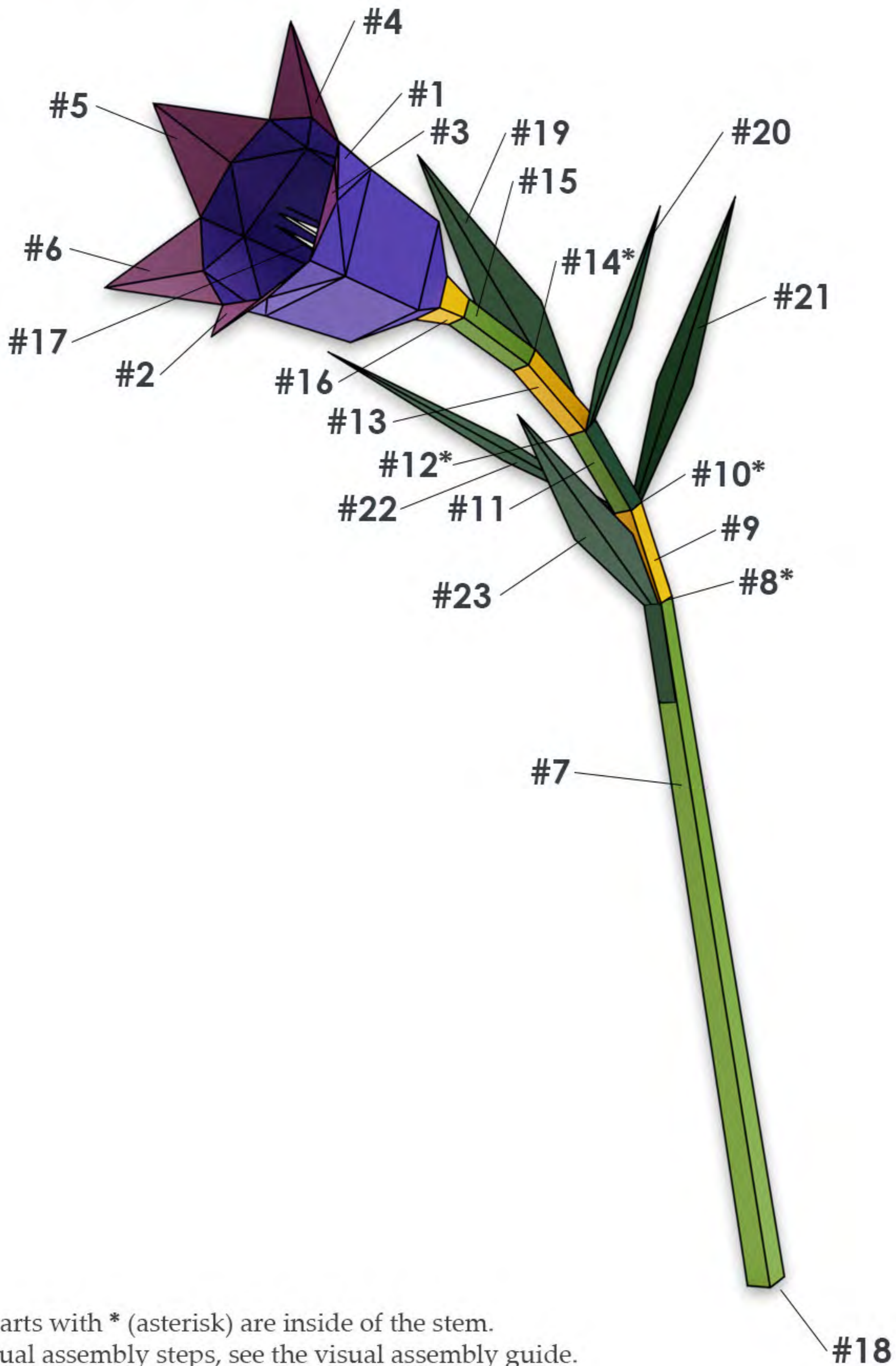

Template parts with \* (asterisk) are inside of the stem.  
For individual assembly steps, see the visual assembly guide.

# VISUAL ASSEMBLY GUIDE

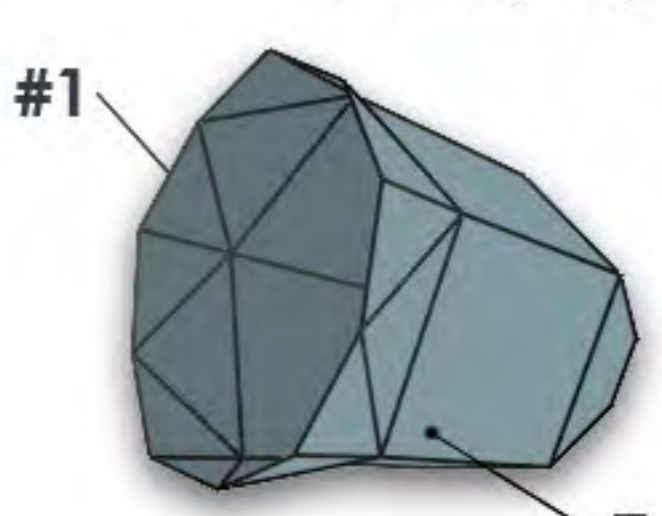
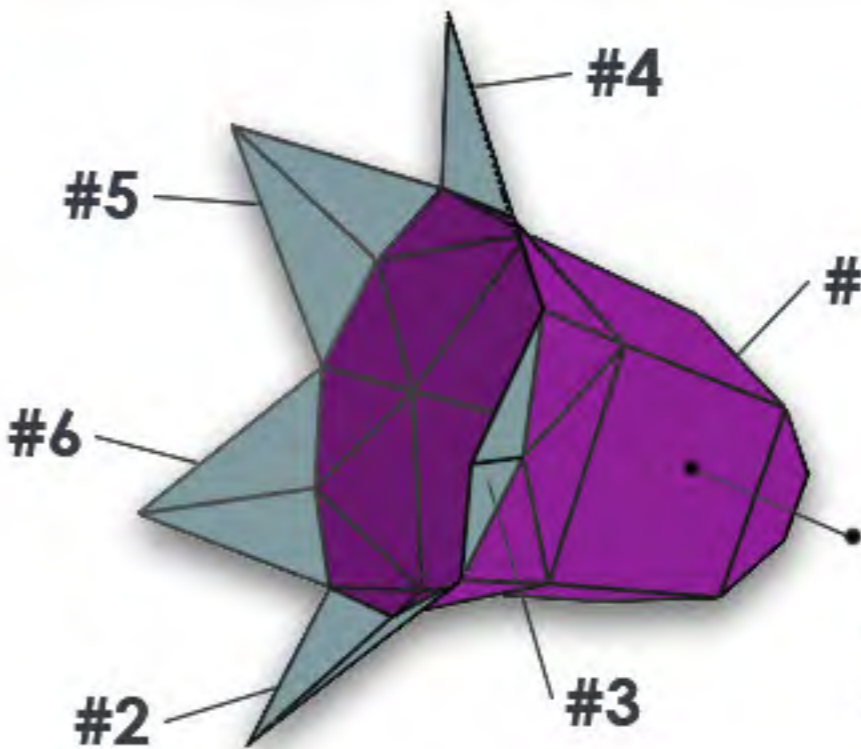
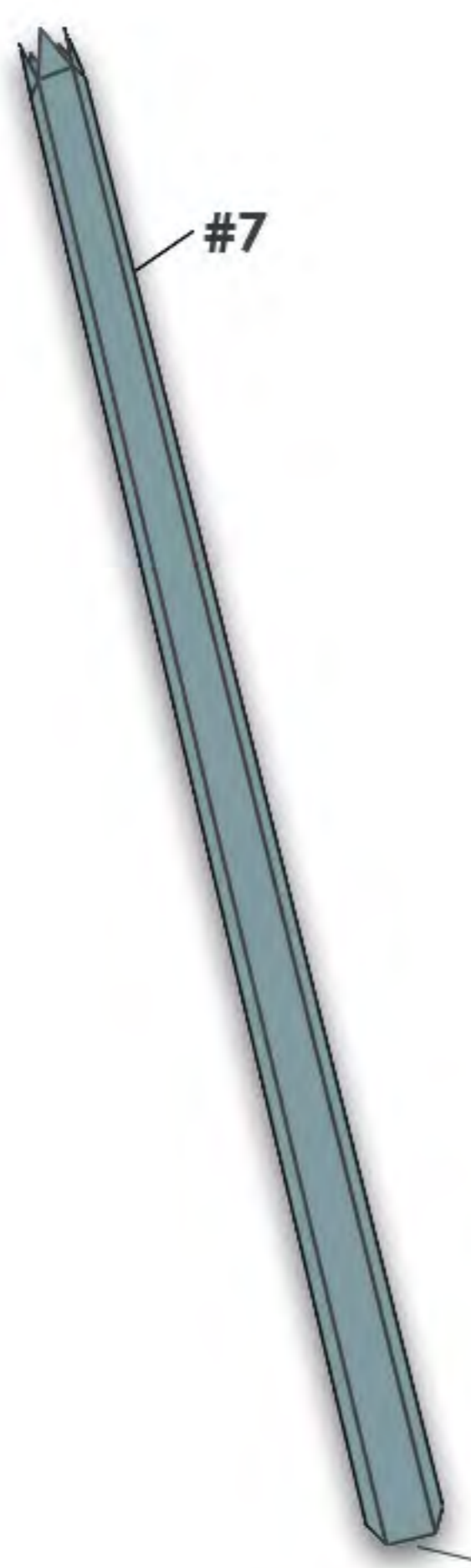
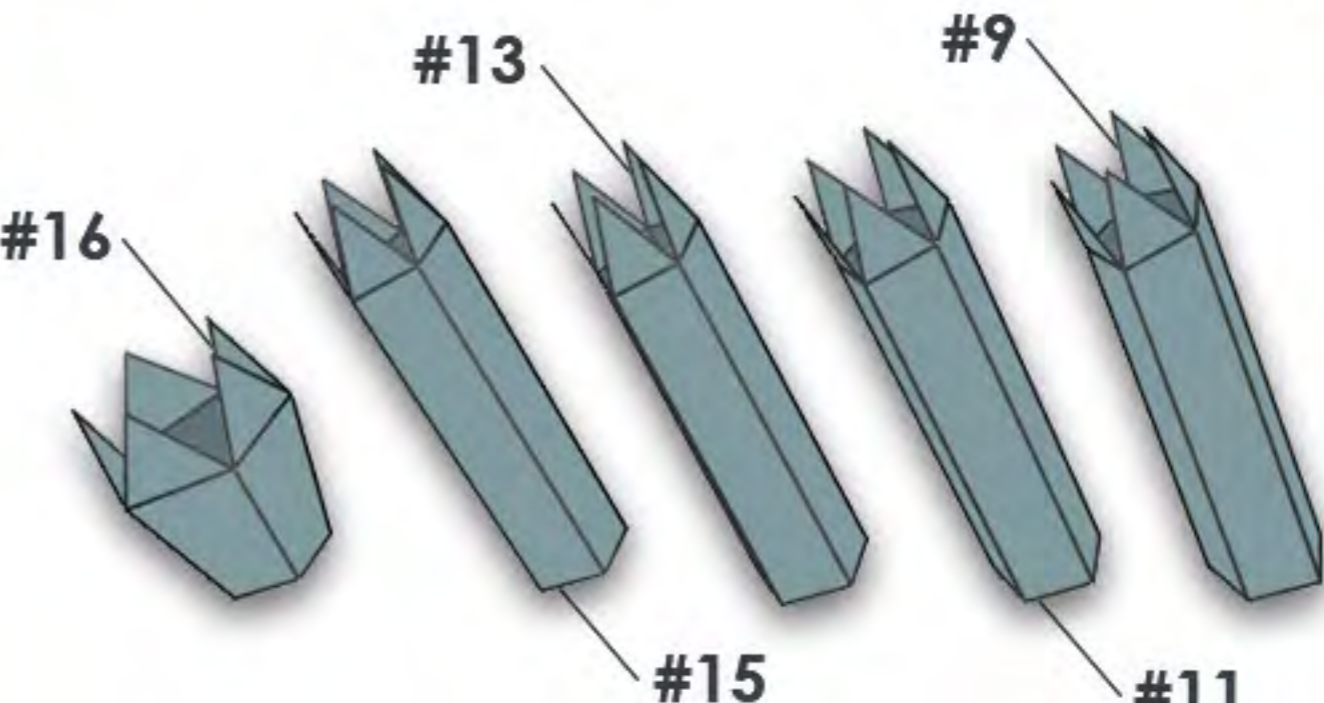
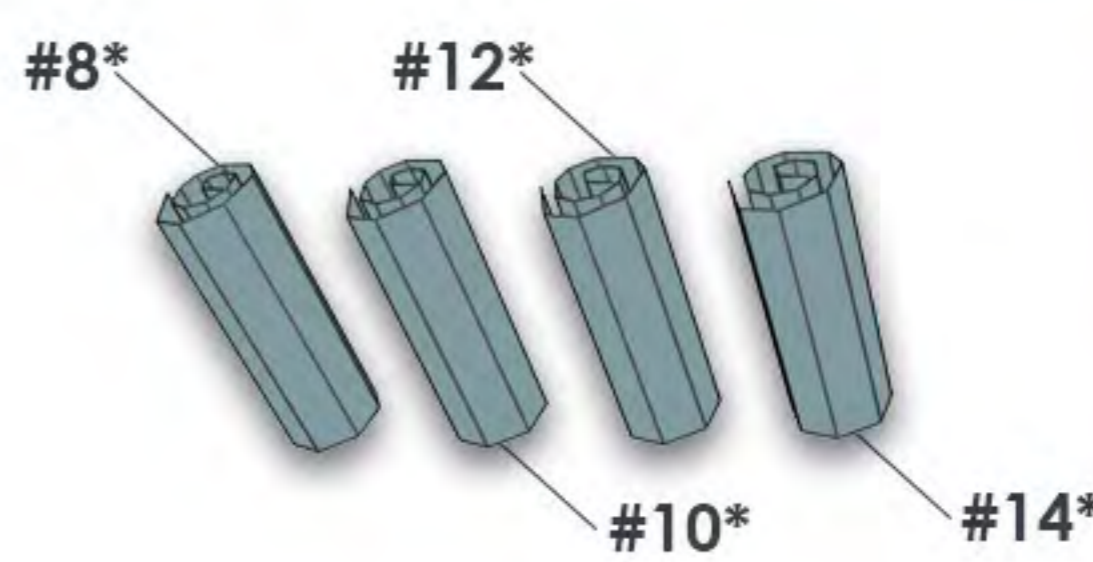
<p>01.</p> <p>Assembly step number.</p>  <p>#1</p> <p>Template part to be assembled in the step.</p> <p>Glue all the flaps within template part #1.</p>	<p>02.</p>  <p>#4</p> <p>#5</p> <p>#6</p> <p>#2</p> <p>#3</p> <p>#1</p> <p>Template part assembled in the previous step(s).</p> <p>Glue template parts #2, #3, #4, #5, and #6 to part #1.</p>
<p>03.</p>  <p>#7</p> <p>#18</p> <p>Assemble stem template parts #7 and #18.</p>	<p>04.</p>  <p>#13</p> <p>#9</p> <p>#16</p> <p>#15</p> <p>#11</p> <p>Separately assemble stem template parts #9, #11, #13, #15, and #16.</p> <p>05.</p>  <p>#8*</p> <p>#12*</p> <p>#10*</p> <p>#14*</p> <p>Roll up template parts #8*, #10*, #12*, and #14*. These are the inner stem parts to support connections of individual stem template parts.</p>

06.

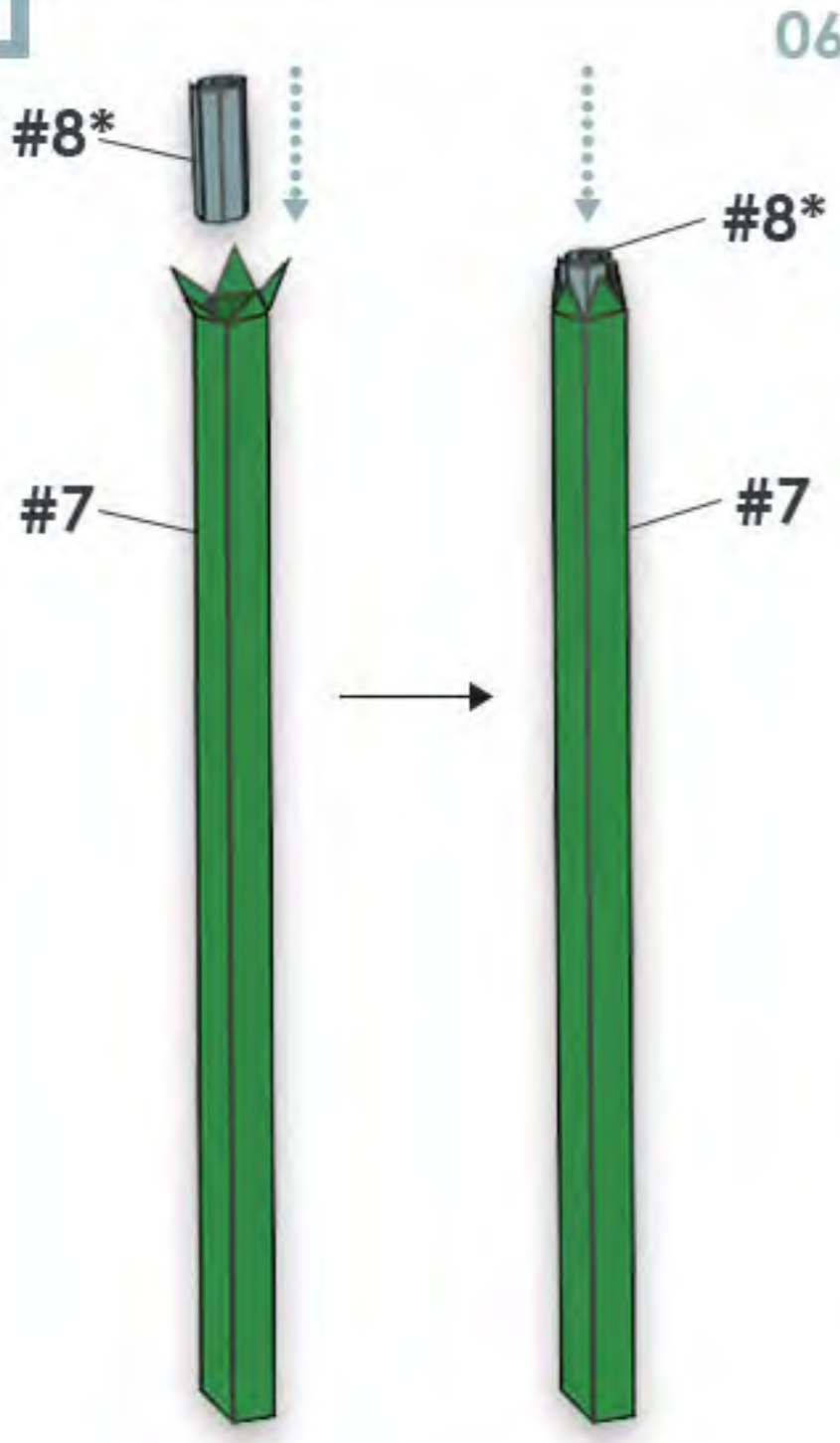

#8\*

#7

#7

#8\*

#7

Apply glue inside template part #7 and insert rolled up template part #8\* into it. Apply glue on all template part #7 flaps and glue them to #8\*.

07.

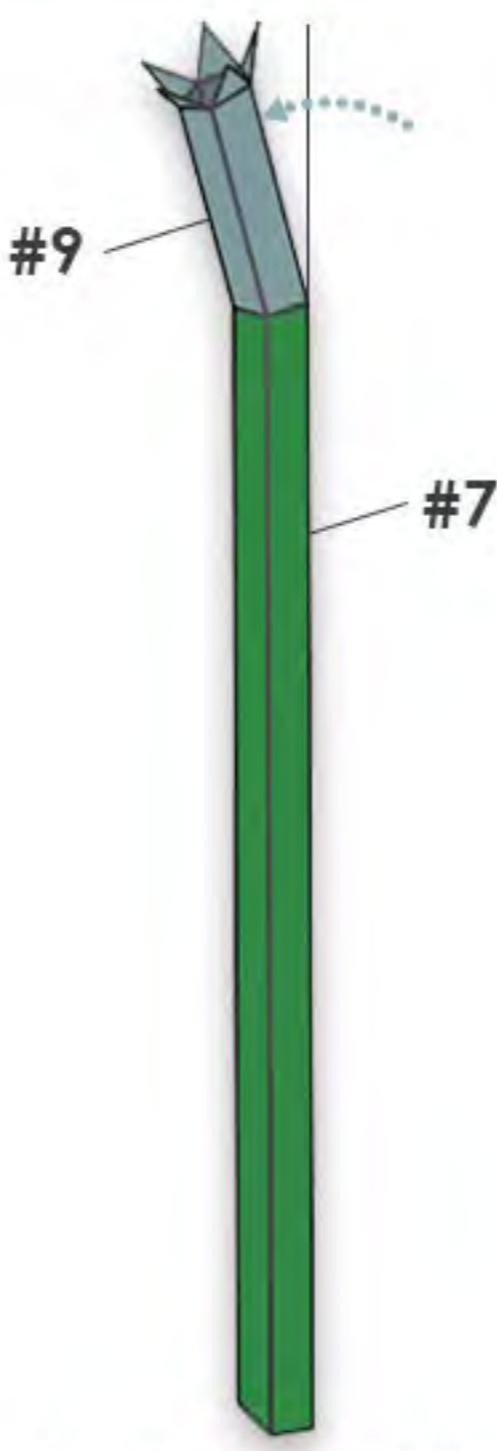

#9

#7

#7

Apply glue inside part #9 and insert it onto part #8\*. Slightly bend freshly glued part #9 to create a curved-looking stem. Wait until glue completely dries, and then move on to the next step.

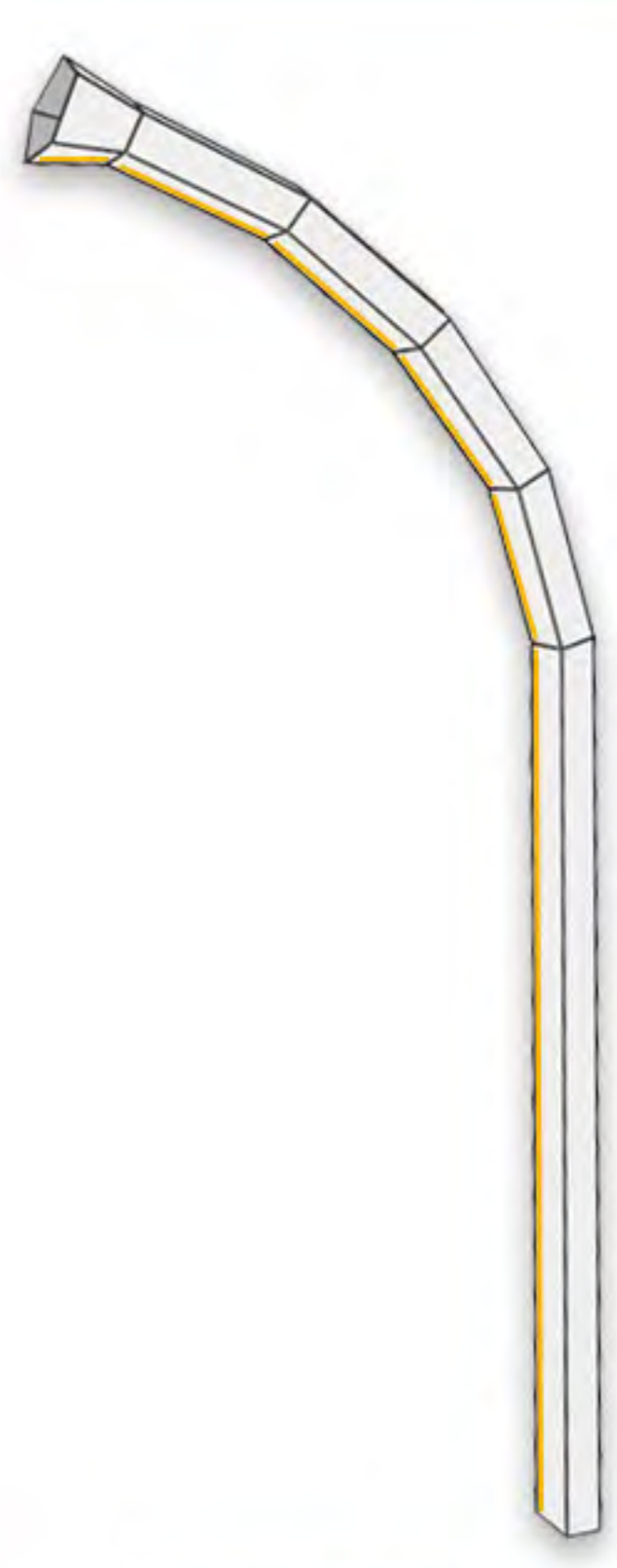

Keep all vertically glued edges of the stem parts aligned at the bottom side of the stem.

08.

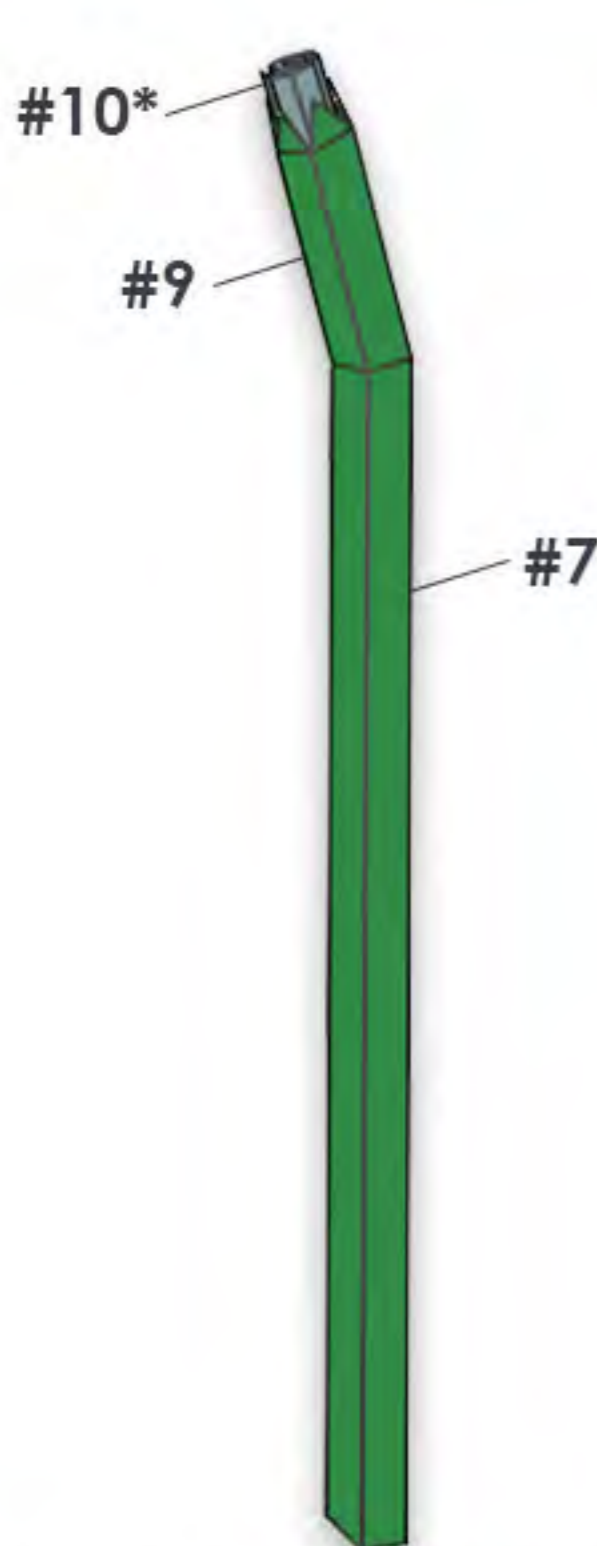

#10\*

#9

#7

#7

Follow the same assembly steps till the stem is completed.

09.

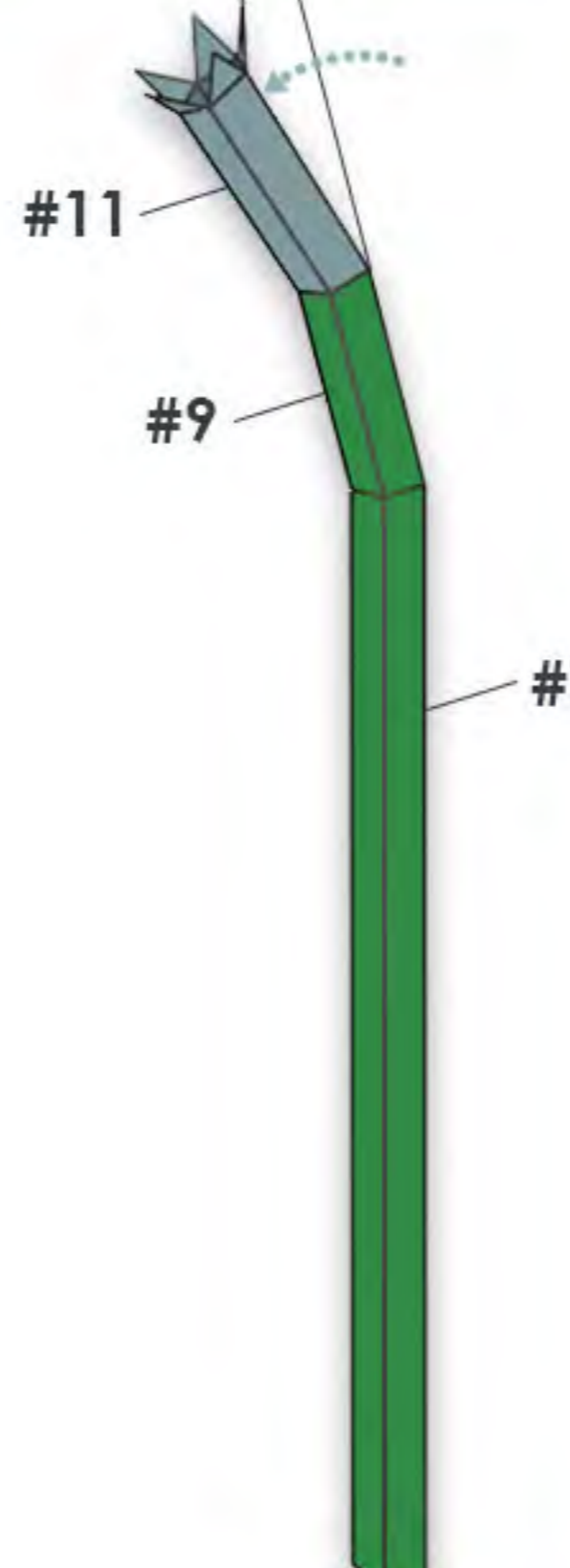

#11

#9

#7

#7

10.

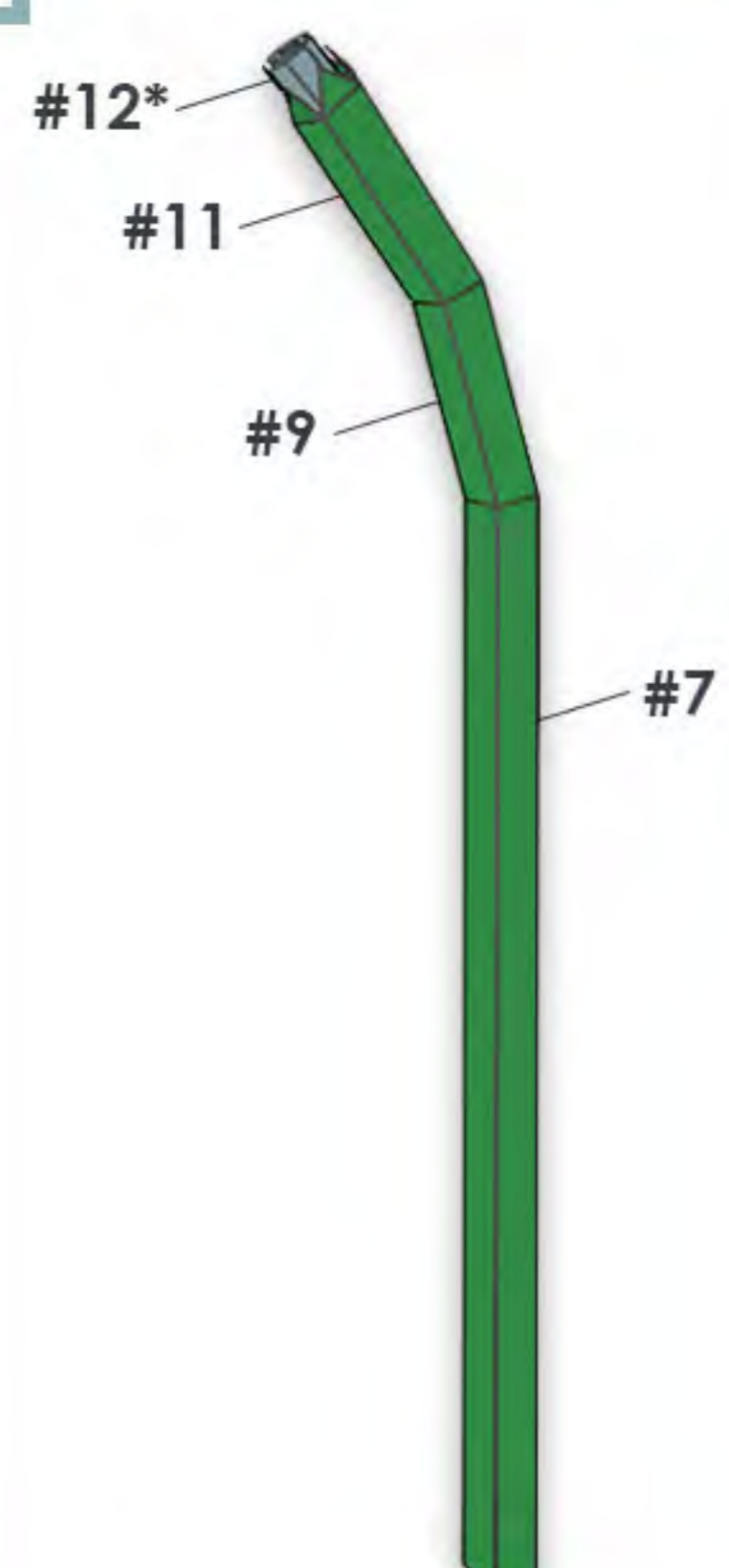

#12\*

#11

#9

#7

#7

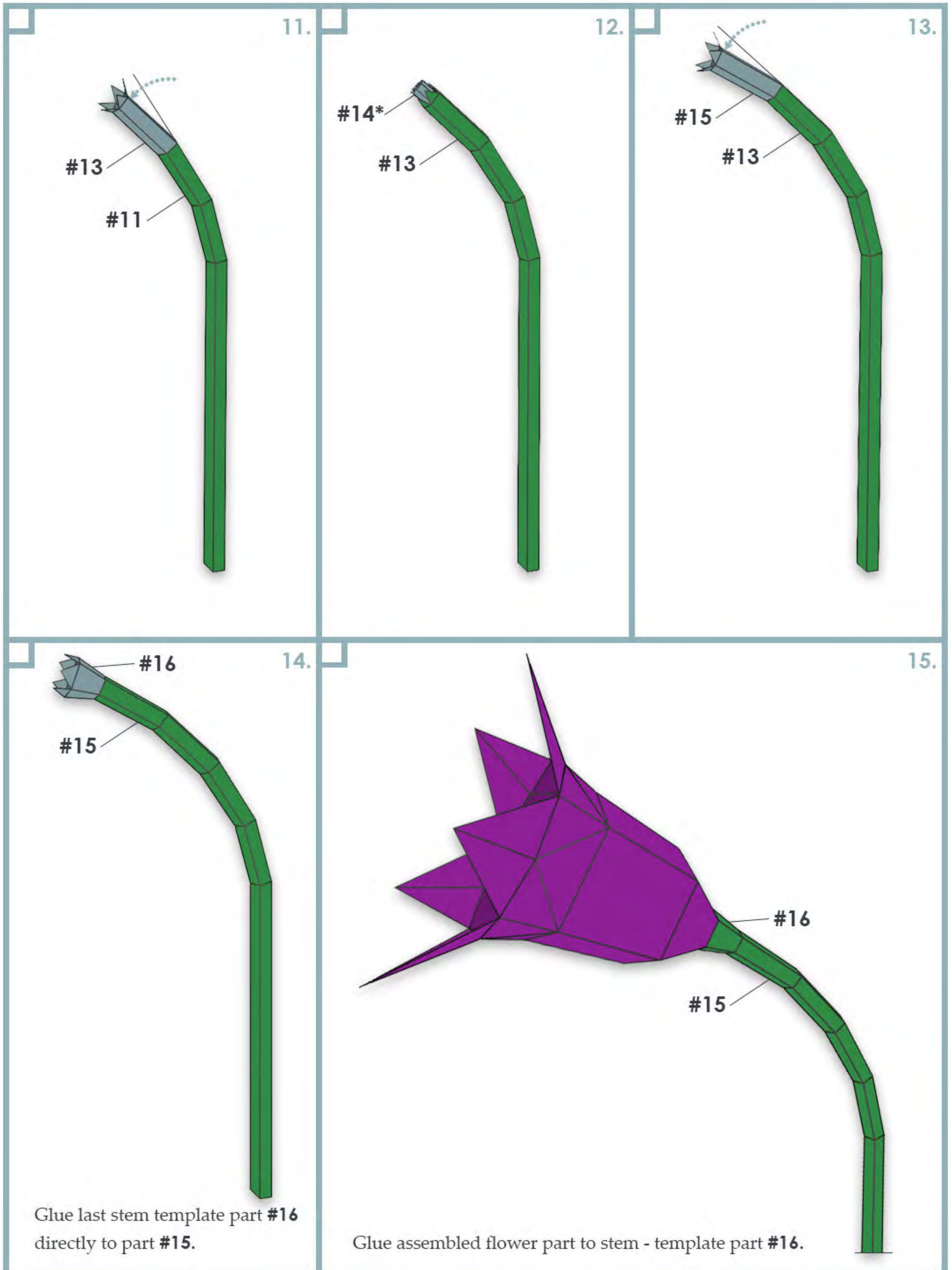

16.

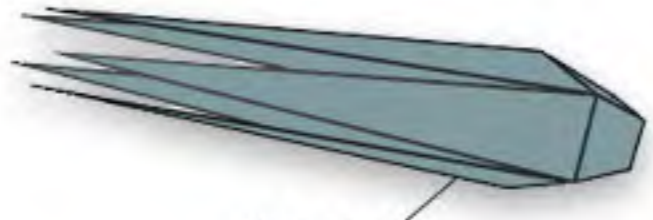

#17

Separately assemble stamens - template part #17.

17.

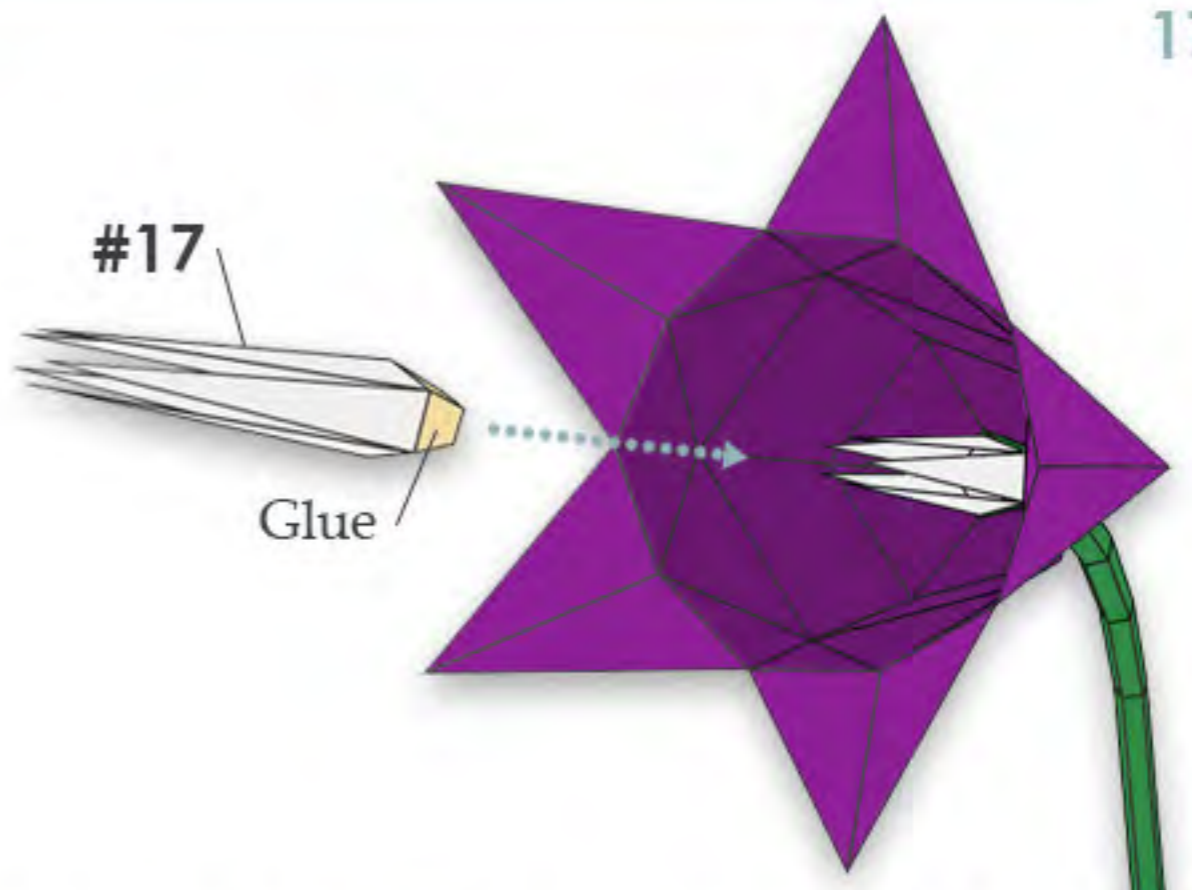

#17  
Glue

Apply glue on the end of stamens part #17 and glue it to the last stem part from inside of the flower part.

18.

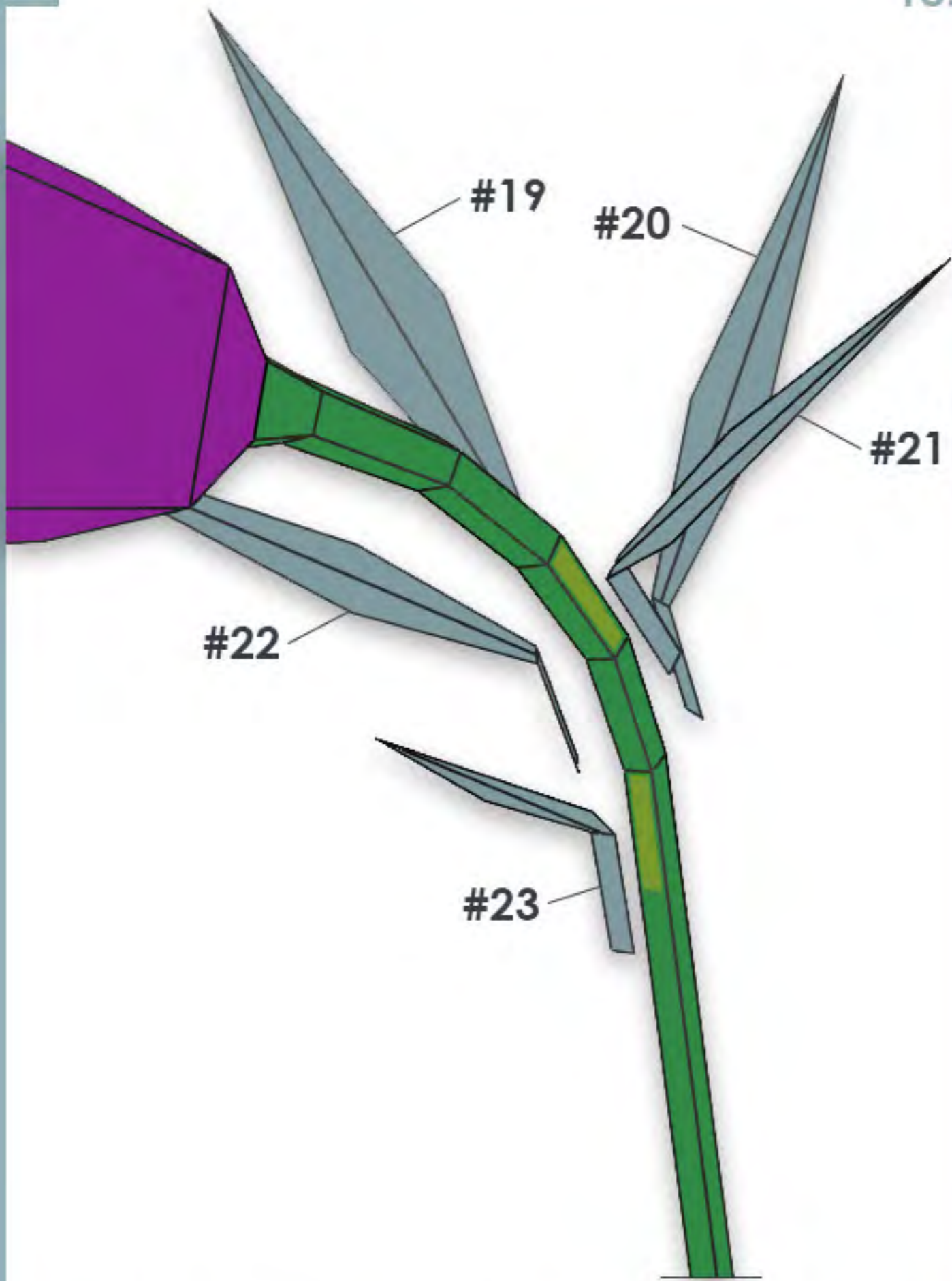

#19 #20 #21 #22 #23

Glue leaves - template parts #19, #20, #21, #22, and #23 to the stem.

19.

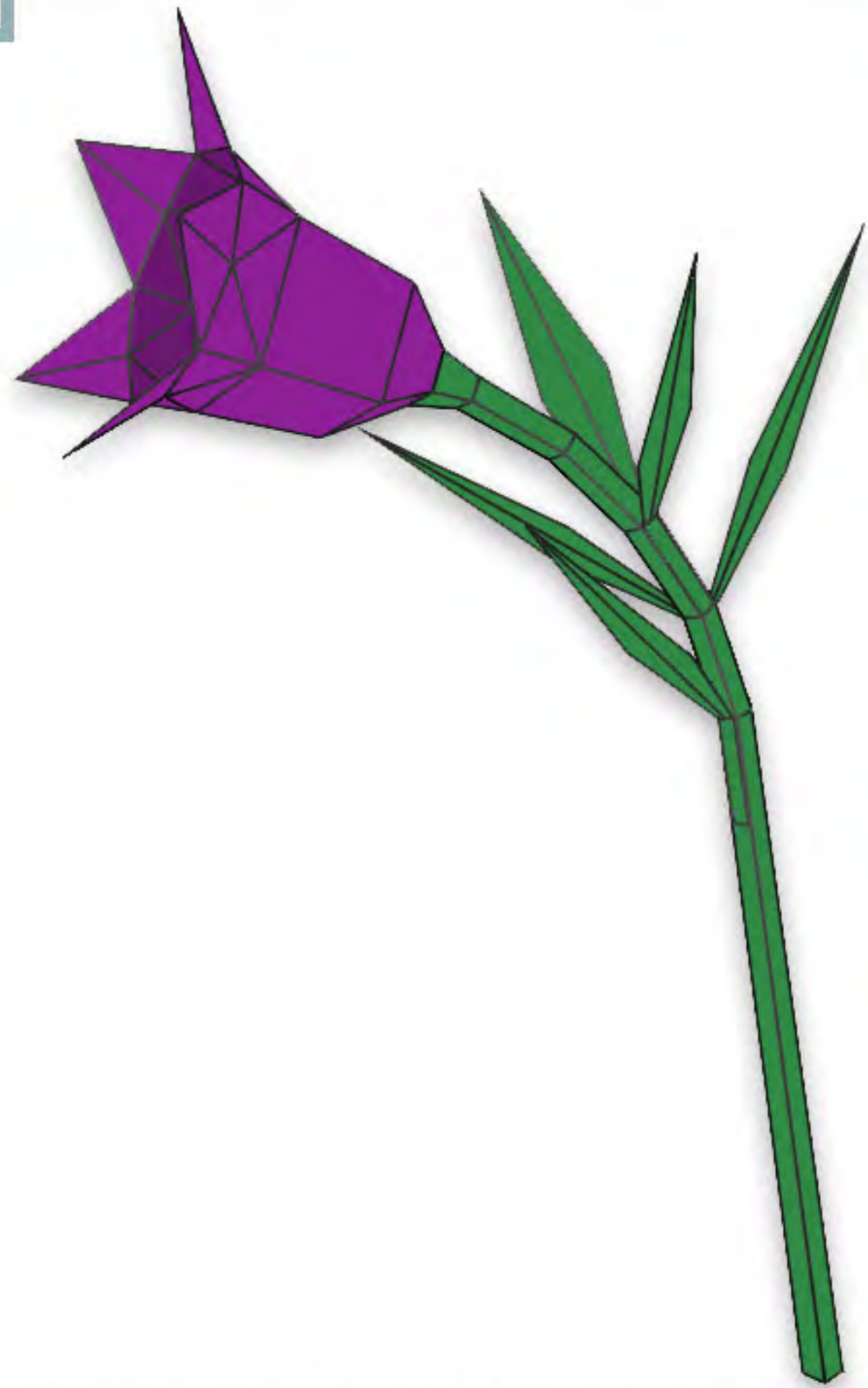

Congratulations! You are done with gluing. Your 3D papercraft BELFLOWER model assembly is complete.

## 06. FINISH □

Finish and decorate your assembled 3D papercraft model using your creativity, personal style, and preferences. Feel free to leave it as it is or paint it over with a technique you like. Nice finishing results can be achieved with a brush and acrylic colors or with color sprays or markers. Creativity has no boundaries as well as your **lowPolysm** 3D papercraft model created with your own hands.

### Finishing tips & tricks:

Excess glue or glue fingerprints visible on your final assembled model can be easily hidden by applying common finishing spray lacquer. Spray your entire papercraft model with a thin layer of transparent water-based finishing lacquer. Your paper model will get a perfect, clean glossy look and will become more durable and firmer.



## ENJOY

We believe you have had a lot of fun on the journey of assembling your own **lowPolysm BELLFLOWER** 3D papercraft model. Now it's time to enjoy the results of your paper crafting and creativity. Decorate your home or office with your completed **lowPolysm** model you made with your own hands or find out how satisfying is to give it to someone as a handmade gift.

We would love to see your final results with any finishing touches you chose to make. Share your assembled **lowPolysm** 3D papercraft model with us on social media with hashtag **#lowPolysm** and follow us on:



Find more of our **lowPolysm** 3D papercraft models and get new inspiration on [lowPolysm.com](https://www.lowPolysm.com).



[www.lowPolysm.com](https://www.lowPolysm.com)

Thank you for your trust, support and feedback. We really appreciate it because it allows us to do what we love and share it with you. If you enjoyed creating this project, then you will be happy to receive coupon code for a **10% discount off** your next **lowPolysm** 3D papercraft adventure!

**COUPON CODE: LOWPOLYSMLOVE**

This **lowPolysm BELLFLOWER** 3D papercraft model, including its design, images, templates, and assembly instructions, is protected by copyright law. It is intended for personal use only. Copying, distributing, selling, or commercially using the templates or assembled models is strictly prohibited. Feel free to create multiple models for personal enjoyment using this template. For any commercial inquiries, please contact us at: [lowpolysm@lowpolysm.com](mailto:lowpolysm@lowpolysm.com).



**SEE ALL OUR 3D PAPER-CRAFTS**